



Overview: model class **G-CLASSIC-30**

Safe and approved storage of flammable or toxic gases in working areas – for up to 4 x 50-litre gas cylinders



Proven technology

- G-CLASSIC-30 gas cylinder cabinets convince due to proven technology

Storage directly in the working area

- safe storage of gas cylinders directly in the working area – 30 minutes fire resistance

Further features of this model class



Locking

- doors lockable with profile cylinder lock
- cabinets can be integrated by the customer in an existing master key system



Pipe lead-throughs

- large area for flexible lead-through possibilities on the top of the cabinet
- no additional insulation of piping necessary



Comfortable adjusting possibilities

- integrated adjusting aids in the cabinet base ensure a fast and effective compensation for uneven floor of up to 10 mm

Possible interior equipment



- **standard interior equipment** complete with mounting rails, cylinder retainer and matching tension belts and rolling ramp



- **lateral cylinder retainer** for two 10-litre cylinders, alternatively in height-adjustable version (no tools required)



- **shelves** in different versions



Safety storage cabinets for the storage of pressurised gas cylinders in working areas according to EN 14470-2 and TRGS 510



- **fire resistance 30 minutes** (type G30), type-tested in accordance with EN 14470-2



- **excellent products with special manufacturer warranty**
- **extended manufacturer warranty of up to 5 years** in combination with the asecos BASICPlus tariff



G-LINE



Gas cylinder cabinet
G-CLASSIC-30 model G30.205.140
 in Light grey (RAL 7035), interior equipment with 1 x standard interior equipment for gas cylinders (sheet steel galvanised and powder coated)
Order No. 30651-001-30652

Technical data		G30.205.140
External dimensions W x D x H	mm	1398 x 616 x 2050
Internal dimensions W x D x H	mm	1294 x 479 x 1874
Weight without interior equip.	kg	545
Extraction air	DN	75
Air change 10 times	m ³ /h	12
Diff. pressure (air change 10 times)	Pa	5
Air change 120 times	m ³ /h	139
Diff. pressure (air change 120 times)	Pa	143 Pa
Distributed load	kg/m ²	507
Maximum load	kg	600
50-litre gas cylinders	piece	4

Technical data		G30.205.120
External dimensions W x D x H	mm	1198 x 616 x 2050
Internal dimensions W x D x H	mm	1094 x 479 x 1874
Weight without interior equip.	kg	485
Extraction air	DN	75
Air change 10 times	m ³ /h	10
Diff. pressure (air change 10 times)	Pa	5
Air change 120 times	m ³ /h	118
Diff. pressure (air change 120 times)	Pa	103 Pa
Distributed load	kg/m ²	560
Maximum load	kg	600
50-litre gas cylinders	piece	4

Safe and approved storage of flammable or toxic gases in working areas – for up to 4 x 50-litre gas cylinders

Function / construction:

- **no unauthorised use:** doors lockable with profile cylinder (integration in an existing locking system possible)
- **easy alignment:** adjusting aids to compensate for uneven floor
- **easy mounting of connecting pipes and gas fittings:** large interior height (1890 mm), many lead-through possibilities on the top of the cabinet
- **ventilation:** integrated air ducts ready for connection (DN 75) to a technical exhaust, even ventilation inside the cabinet

Available equipment

- standard interior equipment – complete with mounting rails, rolling ramp, cylinder retainer and matching tension belts
- lateral cylinder retainer – for two 10-litre cylinders, alternatively in height adjustable version (no tools required)
- cylinder retainer across the entire width of the cabinet



Gas cylinder cabinet
G-CLASSIC-30 model G30.205.120
 in Light grey (RAL 7035), interior equipment with 1 x standard interior equipment for gas cylinders (sheet steel galvanised and powder coated)
Order No. 30663-001-30664
 (lateral cylinder retainer optional)

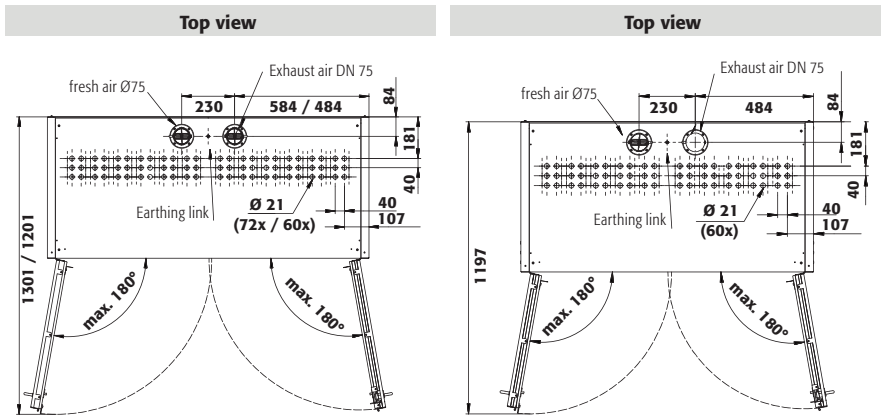
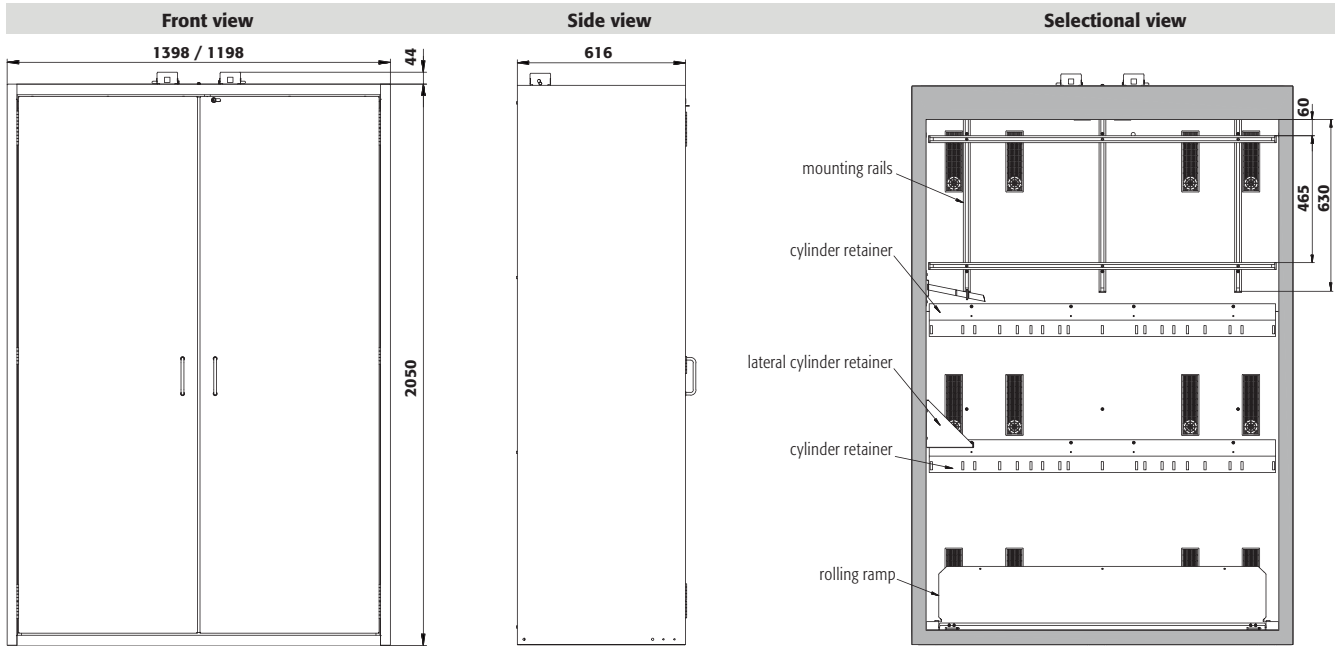

Order example - how to order correctly



2 door colours are available at no extra cost:

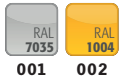

G-LINE

Model	Information / equipment	Order No.	
G30.205.140	without interior equipment	30651	
G30.205.120	without interior equipment	30663	
Body colour	Door colour	Order No.	
Light grey RAL 7035	Light grey RAL 7035	001 4	
Warning yellow RAL 1004	Warning yellow RAL 1004	002 10	
Interior equipment packages (can only be ordered in combination with the cabinet)	Material	Order No.	
G30.205.140 1x standard interior equipment for gas cylinders	sheet steel galvanised and powder coated	30652 4	
G30.205.120 1x standard interior equipment for gas cylinders	sheet steel galvanised and powder coated	30664 4	
Interior equipment	Material	W x D x H (mm)	Order No.
G30.205.140 shelf	sheet steel powder-coated RAL 7035	1281 x 331 x 25*	75.00 30653 2
grid, as storage level	steel galvanised	1233 x 280 x 30	180.00 30654 4
G30.205.120 shelf	sheet steel powder-coated RAL 7035	1081 x 331 x 25*	75.00 30665 2
grid, as storage level	steel galvanised	1033 x 280 x 30	180.00 30666 4
Accessories			Order No.
gas cylinder trolley			26294 2
tension belt, additional			13181 2
preparation for lead-through with female thread			30649 2
Ermeto coupling			5981 2
cylinder retainer, profile as a cylinder retainer incl. 2 tension belts and mounting material flexible mounting in height at the rear wall			30650 2
cylinder retainer on the sidewall			30647 2
cylinder retainer on the sidewall, height adjustable without tools			30648 2

* W x D usable storage space / 1) load capacity (kg), 2) capacity (litres), 3) maximum container volume inside the cabinet (litres)



Safe and approved storage of flammable or toxic gases in working areas – for up to 3 x 50-litre gas cylinders

Function / construction:

- **no unauthorised use:** doors lockable with profile cylinder (integration in an existing locking system possible)
- **easy alignment:** adjusting aids to compensate for uneven floor
- **easy mounting of connecting pipes and gas fittings:** large interior height (1890 mm), many lead-through possibilities on the top of the cabinet
- **ventilation:** integrated air ducts ready for connection (DN 75) to a technical exhaust, even ventilation inside the cabinet

Available equipment

- standard interior equipment – complete with mounting rails, rolling ramp, cylinder retainer and matching tension belts
- lateral cylinder retainer – for two 10-litre cylinders, alternatively in height adjustable version (no tools required)
- cylinder retainer across the entire width of the cabinet



**Gas cylinder cabinet
G-CLASSIC-30 model G30.205.090**

in Light grey (RAL 7035), interior equipment with 1 x standard interior equipment for gas cylinders (sheet steel galvanised and powder coated)

Order No. 30673-001-30674

Technical data		G30.205.060
External dimensions W x D x H	mm	598 x 616 x 2050
Internal dimensions W x D x H	mm	494 x 479 x 1874
Weight without interior equip.	kg	290
Extraction air	DN	75
Air change 10 times	m ³ /h	4
Diff. pressure (air change 10 times)	Pa	5
Air change 120 times	m ³ /h	53
Diff. pressure (air change 120 times)	Pa	85 Pa
Distributed load	kg/m ²	921
Maximum load	kg	600
50-litre gas cylinders	piece	2

Technical data		G30.205.090
External dimensions W x D x H	mm	898 x 616 x 2050
Internal dimensions W x D x H	mm	794 x 479 x 1874
Weight without interior equip.	kg	340
Extraction air	DN	75
Air change 10 times	m ³ /h	7
Diff. pressure (air change 10 times)	Pa	5
Air change 120 times	m ³ /h	86
Diff. pressure (air change 120 times)	Pa	147 Pa
Distributed load	kg/m ²	648
Maximum load	kg	600
50-litre gas cylinders	piece	3



**Gas cylinder cabinet
G-CLASSIC-30 model G30.205.060**

in Light grey (RAL 7035), interior equipment with 1 x standard interior equipment for gas cylinders (sheet steel galvanised and powder coated)

Order No. 30685-001-30687



Front view

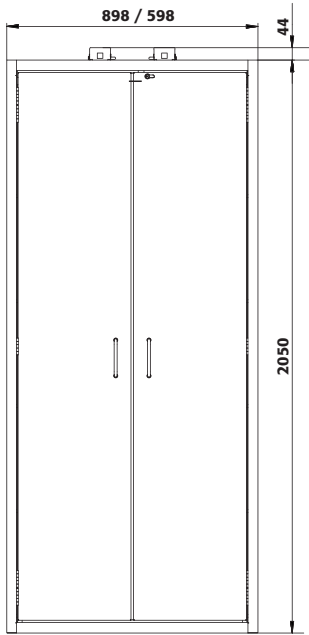

Side view



Selectional view

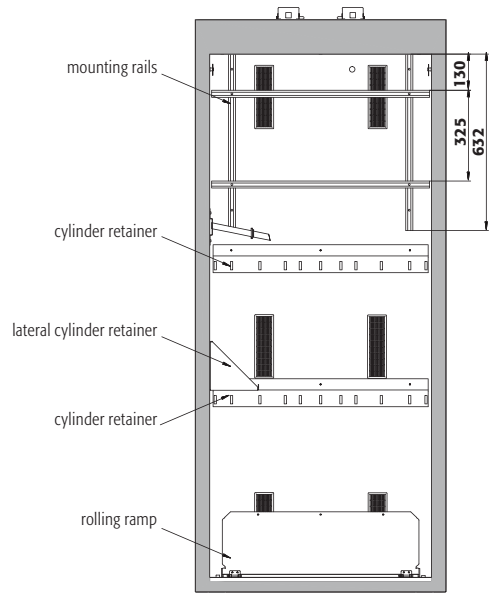

Top view

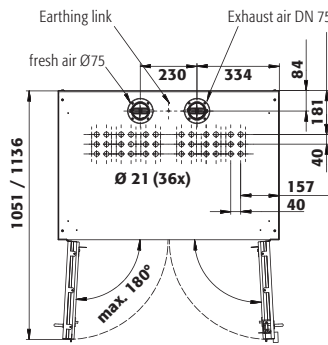

Top view

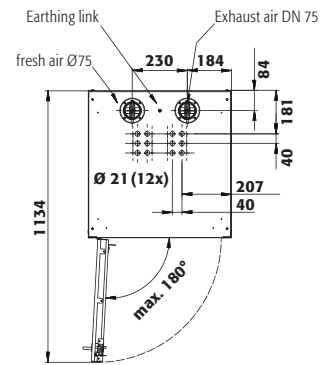

Order example - how to order correctly



2 door colours are available at no extra cost:

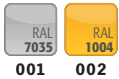

G-LINE

Model	Information / equipment	Order No.
G30.205.090	without interior equipment	30673
G30.205.060	without interior equipment, left hinged	30685
G30.205.060.R	without interior equipment, right hinged	30686

Body colour	Door colour	Order No.
Light grey RAL 7035	Light grey RAL 7035	001 4
Warning yellow RAL 1004	Warning yellow RAL 1004	002 10

Interior equipment packages (can only be ordered in combination with the cabinet) G30.205.090	Material	Order No.
1x standard interior equipment for gas cylinders	sheet steel galvanised and powder coated	30674 4

Interior equipment packages (can only be ordered in combination with the cabinet) G30.205.060(R)	Material	Order No.
1x standard interior equipment for gas cylinders	sheet steel galvanised and powder coated	30687 4

Interior equipment G30.205.090	Material	W x D x H (mm)	1) 2) 3)	Order No.
shelf	sheet steel powder-coated RAL 7035	782 x 337 x 25*	75.00	30675 2
grid, as storage level	steel galvanised	733 x 280 x 30	180.00	30789 4

Interior equipment G30.205.060(R)	Material	W x D x H (mm)	1) 2) 3)	Order No.
shelf	sheet steel powder-coated RAL 7035	482 x 337 x 25*	75.00	30688 2

Accessories	Order No.
cylinder retainer, profile as a cylinder retainer incl. 2 tension belts and mounting material flexible mounting in height at the rear wall	30650 2
cylinder retainer on the sidewall	30647 2
cylinder retainer on the sidewall, height adjustable without tools	30648 2
Ermeto coupling	5981 2
preparation for lead-through with female thread	30649 2
tension belt, additional	13181 2
gas cylinder trolley	26294 2

* W x D usable storage space / 1) load capacity (kg), 2) capacity (litres), 3) maximum container volume inside the cabinet (litres)